

Profile



Phocos is one of the largest suppliers of off-grid power supply system components in the world. Headquartered in Ulm, Germany, Phocos develops, designs and manufactures products to suit the needs of all stake-holders in the global solar power market.

Technology

Phocos is strongly committed to developing and producing products that meet our strict specifications in terms of quality, innovation and technology. Our highly-skilled Research and Development team works in close collaboration with the University of Applied Science of Ulm and distinguished institutes in Germany to produce components which greatly enhance the life-span of the battery and improve the efficiency of the solar power system.

Reliability & Cost

Key issues in the off-grid rural electrification market are reliability and cost. The rugged and advanced technology used in Phocos charge controllers and products ensures greater reliability, improves the overall efficiency of the system and lowers the costs of energy storage.

Specialty in Off-grid Application

We offer a cutting edge range of components for off-grid power supply systems including a comprehensive range of solar charge controllers, system management units, DC fluorescent lamps and refrigerators, micro-hydro turbines and fuel-cell hybrid systems. Our products are versatile and suitable for a wide range of applications such as industrial power supplies, telecommunications, traffic control, lighting and for leisure purposes such as boating and sailing.

Flexibility

Our ability to respond to our customer's specific needs enables us to offer highly sophisticated and customised solutions for use in larger industrial systems or in low cost stand-alone systems for large rural electrification projects.

Worldwide Network

Our extensive distribution network ensures that our products are accessible all over the world, while our team of highly experienced engineers in Germany and through our subsidiaries provide the necessary technical back-up and support.

Phocos has operations in Germany, China, India, Bolivia, Bangladesh, Australia, Brazil, Japan, Kenya, Mongolia, Romania, Singapore, South Africa and the USA.

More information is available online at www.phocos.com

Products Application Range

Phocos products can meet your requirements for solar stand alone systems.

Recreational System



Solar Power Lighting System



Rural Electrification System



Solar Power Supply for Industrial & Telecom System

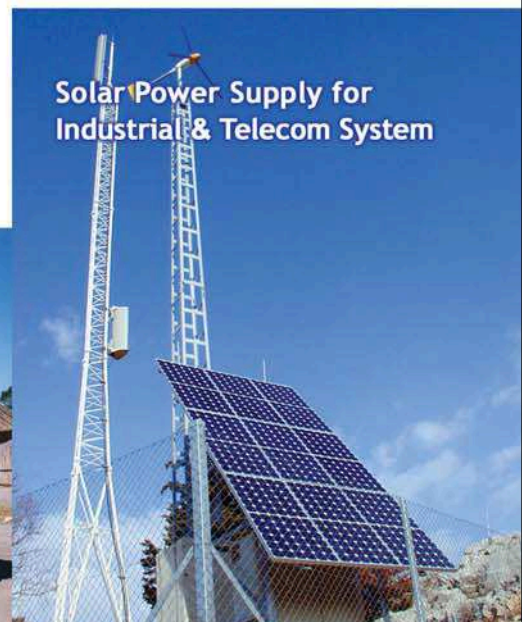

This page gives a quick overview of the different Phocos charge controllers. From uniqueness of features to power range Phocos offers various products designed for each specific market requirements. Phocos charge controllers have a very low failure rate, however we offer two years of warranty.

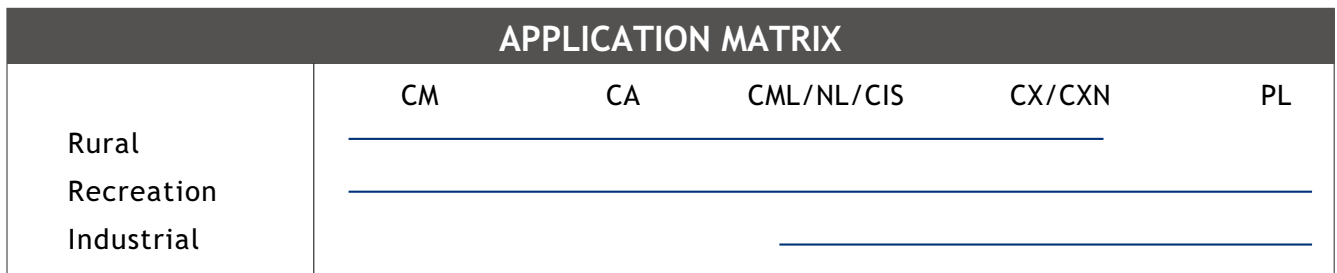
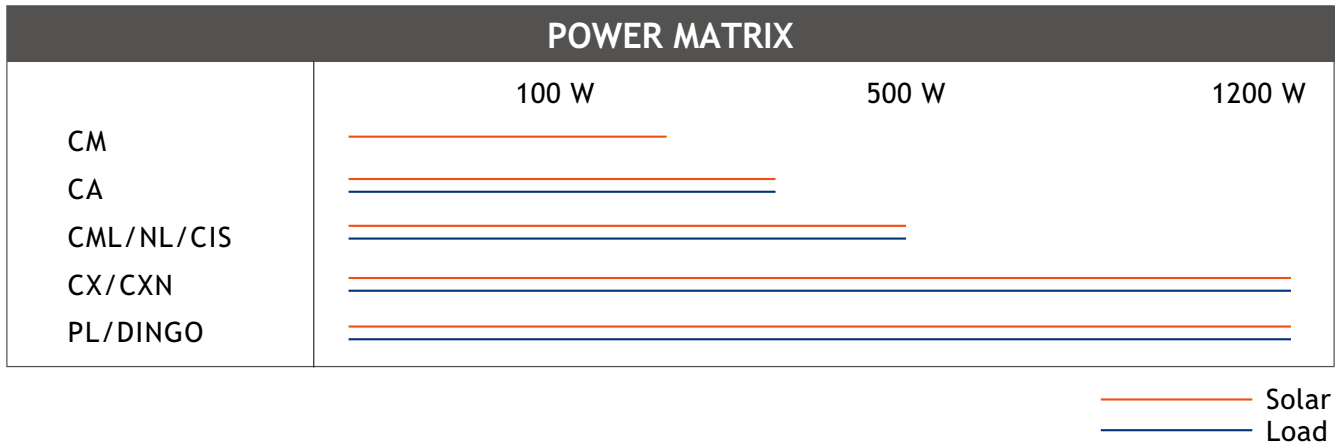

FEATURE MATRIX

	CM	CA	CML/NL	CX/CXN	PL
12V	●	●	●	●	●
12/24 Automatic			●	●	●
48 V					●
LVD		●	●	●	●
Temp.Compensation	●	●	●	●	●
Equalize Mode			●	●	●
PC Interface/Datalogging				●	●
Remote Display		●	●	●	●



MPPT Maximum Power Point Tracker

Innovative Maximum Power Point Tracking Technology Increases System Efficiency and Reduces System Cost.

- Maximum Power Point Tracking Technology**

With innovative maximum power point tracking technology, Phocos' Maximum Power Point Tracker ensures maximum performance from your solar array at all times and in any weather conditions. The MPPT can yield an energy gain of up to 30% from your PV system. Depending on the ambient temperature and the weather conditions, an increase of 10 to 15% can typically be achieved.

- Use Solar Panels for Grid-Feed-in Systems**

The possibility to use less expensive grid-feed-in solar panels with up to 95 V open circuit voltage for 12 V or 24 V stand-alone-systems will significantly reduce cost of the total system.

- Three Stage I-U Curve Charge Regulation**

The temperature-compensated three stage I-U curve charge regulation algorithm significantly extends the life span of your battery.

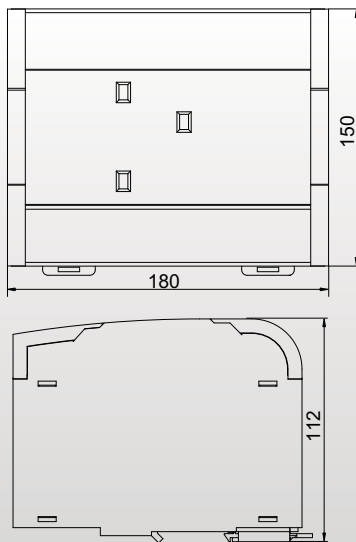

Technical Data	MPPT100/20
Nominal Voltage	12/24 V, automatic recognition
Max. PV Power	12 V-300W, 24V-600W
Max. Solar Input Voltage Voc	95 V
Max. Battery Charge Current	20 A
Power Conversion Efficiency	up to 97%
Standby Power Consumption	<30 mW@12 V system voltage(<2 mA) <80 mW@24 V system voltage(<3 mA)
Temperature Compensation	-4 mV/cell*K
Max. Wire Size	32 mm ² (AWG#2)
Ambient Temperature Range	-25°C to +50°C
Weight	1581 g

During the day there is quite a significant amount of time where the PV generator will not operate at its full rated power but in its lower power range. Bad weather conditions increase those hours per day due to the lack of direct sunlight on the PV panel. Thus, in these scenarios, if the MPPT has a poor efficiency rating in the lower power levels the battery cannot be charged optimally, and the power gain from the PV panel cannot be realized. The Phocos MPPT100/20 was designed in a way that allows it to perform at a high efficiency whenever it charges the battery.

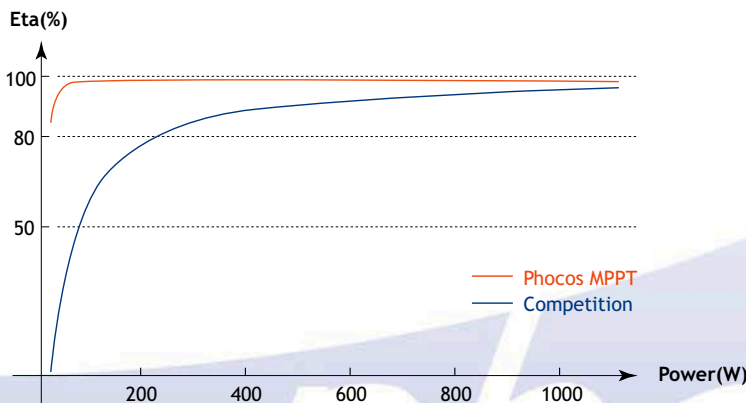

The Phocos MPPT100/20 was designed in order to yield all benefits of Maximum Power Point Tracking. Its efficiency is comparably high even on the lowest power levels. This means that the MPPT100/20 keeps charging even in cloudy or rainy seasons where batteries cannot always be fully charged.



CX/CXN Solar Charge Controller

Phocos CX/CXN Series is a Sophisticated Solar Charge Controller Which Offers Exceptional Features at an Extremely Competitive Price.

- Data Logging**
 The CX/CXN charge controller stores system data for one year.
- High Reliability Design**
 Superior design ensures high degree of reliability through PCB conformal coating and anti-corrosive screws and terminals. Full electronic protection against short circuits, overload, overcurrent, reverse flow, wrong polarity and over-temperature.
- Multifunctional LCD Display**
 The SOC bar indicates the exact state of charge (available energy) as a percentage through the battery gauge symbol. Load status and nightlight function are displayed symbolically.
- Negative Grounding (CXN)**
- Various Optional System Accessories**

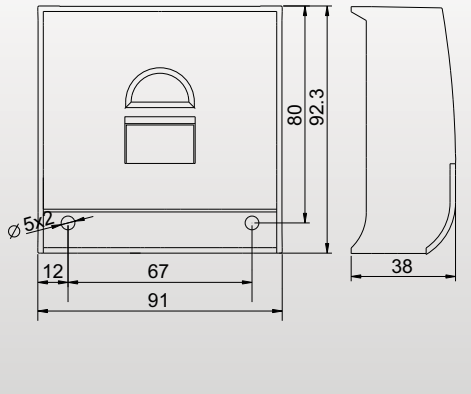

Technical Data	CX/CXN10	CX/CXN20	CX/CXN40
Nominal Voltage	12/24 V, automatic detection		
Max. Solar Panel Current	10 A	20 A	40 A
Max. Load Current	10 A	20 A	40 A
Overcharge Protection	Constant voltage PWM series regulation: boost charge, float charge and optional equalization charge.		
Overdischarge Protection Selectable LVD Modes	High or low fixed voltage setting; high or low SOC (state of charge); adaptive low voltage disconnect (fuzzy logic algorithm)		
Ambient Temperature Range	-25 °C to +50 °C		
Max. Wire Size	16 mm ² (AWG#6)		
Self Consumption	4 mA		
Weight	166/170 g	166/170 g	176/180 g

Low Voltage Disconnect Function:

The CXN controller has five different modes to protect the battery from deep discharging:

Mode 1: Disconnect at 11.4 V (at nominal load current) to 11.9 V (at no load current). Normal operation mode for good battery protection.

Mode 2: Disconnect at 11.0 V (at nominal load current) to 11.75 V (at no load current). Mode with lower disconnection point. Battery is cycled deeper, which can shorten battery lifetime.

Mode 3: Disconnect at 11.0 to 12.2 V depending on load current and previous charging cycles. This adaptive mode leads to a longer battery lifetime because it allows recovery of the battery by full recharge, thus maximizing battery life.

Mode 4: Disconnect at 11.5 V fixed setting. Appropriate if bypass loads draw current directly from battery.

Mode 5: Disconnect at 11.0 V fixed setting. Appropriate if bypass loads draw current directly from battery. Mode with lower disconnection point. Battery is cycled deeper, which can shorten battery lifetime.

Flexible Nightlight Function:

Automatically detects day/night.

Programmable day/night threshold (light on/off point).

Lighting timing modes include dusk to dawn and ON/OFF/ON.

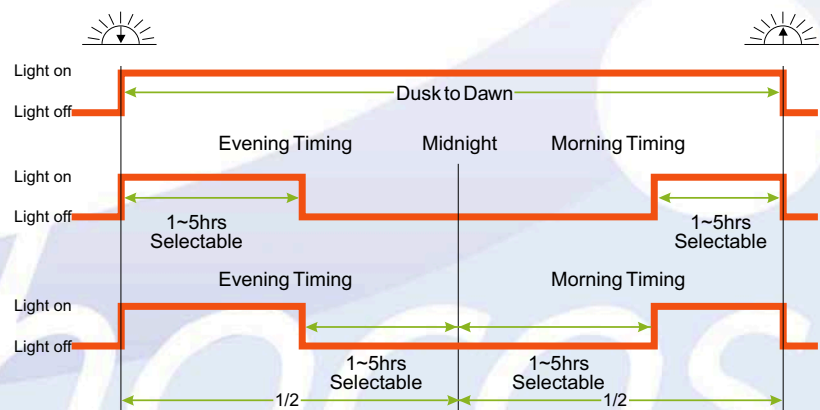

CX/CXN Solar Charge Controller

There are Various Optional Accessories for CX/CXN Solar Charge Controller

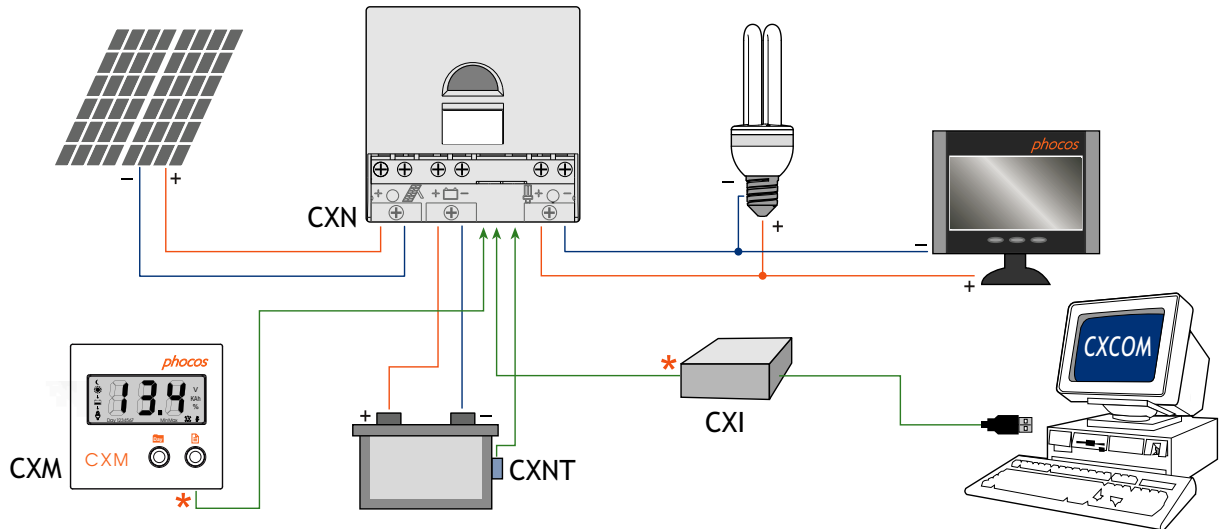

CXM: Remote Display

- Display panel current, load current and battery voltage, Ah, SOC, etc.
- Clear, readable three-digit LCD display and symbols

Software and Precise Datalogger System for Automatic Data Recording and Fault Analysis in Stand-Alone Systems

Through the CXI USB interface and the CXCOS software, users can now gain immediate and easy access to the CXN solar controller directly from their computer.

CXI: USB Interface for CXN/CX Series Controllers

- The CXN/CX charge controller is connected to the computer via a USB plug
- The CXI is a device which allows the CXN/CX series solar controllers to communicate with a computer
- The CXI converts signals from the charge controller into a format which is easily read and interpreted by the computer

CXCOS: Application Software

- Allows the CXN/CX controller to communicate with computer
- Displays the current state and historical data of the system
- Information can be saved in an Excel or Text file format
- Displays and allows modification of the controller settings, including battery type, buzzer, programming button, low voltage disconnect function, nightlight function, etc.

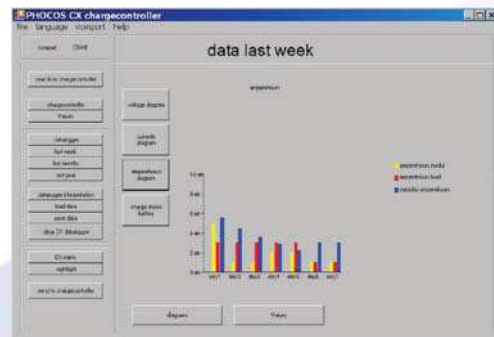
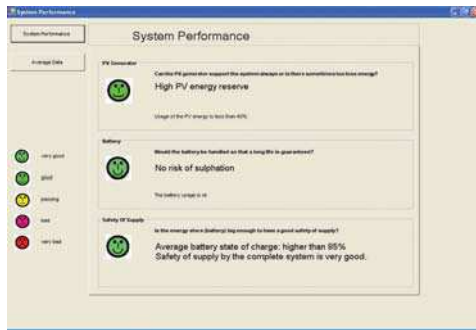

The system performance analysis provides insights for problem solving.

CXNT: External Temperature Sensor

CXNT measures the battery temperature. CXN can adjust charging voltage accordingly.

CIS Industrial Solar Charge Controller

The CIS incorporates the latest technology, highest-quality and best possible cost/performance ratio. Its smart, rugged design meets industrial standards for any small off-grid solar application.



- **Robust and Compact Aluminum Housing (IP68)**

In order to ensure reliable battery charge control under extreme weather / environmental conditions (street lights, navigation buoys, etc.), the CIS was designed with an epoxy-encapsulated PCB to prevent corrosion. CIS is mounted within a durable aluminum housing which provides no moving parts or other potential breach points. The extremely compact housing allows for installation inside tight spaces such as streetlight poles.

- **Intelligent Timer Functions/Multi-LED Status and Infrared Remote Control**

The CIS microchip provides flexible and intelligent load control for various lighting applications. It is possible to customize the timer functions by reference set points, low-voltage disconnect thresholds and hours per day time. All settings are adjusted via CIS-CU remote control. The CIS displays operation, failure and time-mode status of the system via a three LED display.

- **Single and Dual Load Output Options**

CIS is available with one (1) or two (2) load outputs allowing multiple lighting apparatus to be controlled simultaneously or one apparatus with light dimming option. These features allow for a variety of load timing and power-saving options for lighting or other timed load control applications.

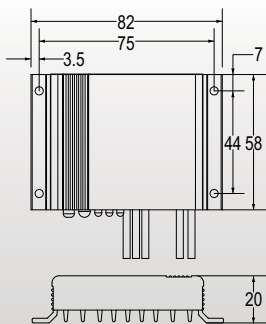

Technical Data	CIS05/10/20; CIS05-2L
Nominal Voltage	12/24 V, automatic detection
Max. Solar Panel Current	5 A/10 A/20 A
Max. Load Current	5 A/10 A/20 A
Overcharge Protection	Constant voltage PWM series regulation: boost charge, float charge, optional equalization charge.
Overdischarge Protection	11.4-11.9/22.8-23.8 V controlled by state of charge(SOC)
Selectable LVD Modes	11.0/22.0 V controlled by fixed battery voltage
Ambient Temperature Range	-40 °C to +60 °C
Max. Wire Size	1,5 mm /2,5 mm
Self Consumption	5-8 mA @ 12V, 6-10 mA @24 V
Weight	150 g
Menu Setup	Via infrared remote control

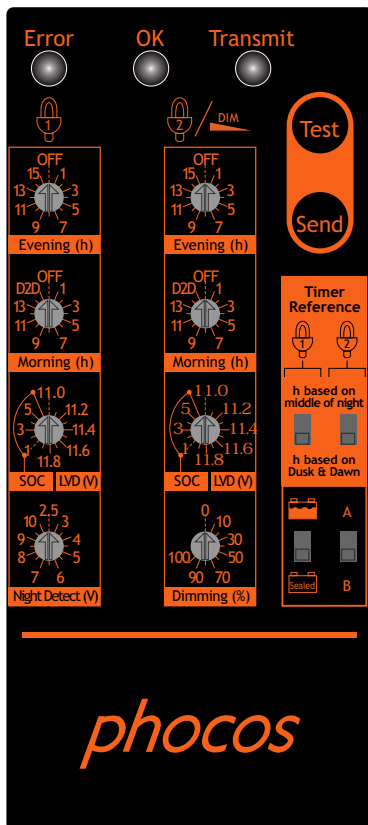

CIS-CU Infrared Remote Control

The CIS offers an integrated programming interface feature that enables all settings to be adjusted quickly and easily via an optional remote control. One remote control can be used to program an infinite number of CIS-controlled systems.

The controller will send and receive the infrared signal from the CIS charge controller within a distance of up to five meters. This can vary based on conditional parameters such as dust and/or dirt on the LEDs or light diffusion.

The following parameters can be adjusted via remote control: Time settings and reference points, battery type, deep discharge protection and the day/night detection threshold.

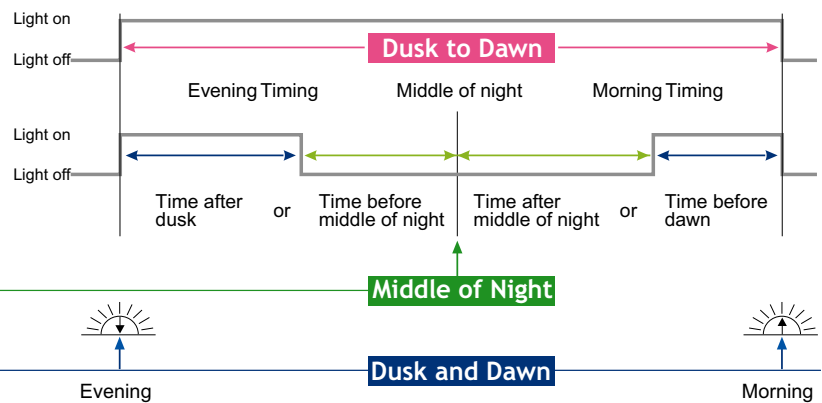

Deep-Discharge Protection (LVD/SOC):

The CIS remote control allows to adjust ten different voltage thresholds and six state of charge controlled levels to customize the deep discharge protection feature.

- **Nightlight Off:**

Load output stays active all day. A load can be supplied which does not require a day/night timer for activation (e.g. a load in a room without windows).

- **Dusk to Dawn**

The load output is switched on the whole night.

- **Reference: Dusk and Dawn**

The load output is activated from dusk and stops after a programmed number of hours. In addition, the output can be programmed to activate the load again based on a number of hours before dawn.

- **Reference: Middle of Night**

The load output is activated from dusk until dawn, but stops during a programmed set of hours before and after the middle of the night. The settings made for this mode define the pause (load off) time between lighting sequences.

- **Dimming**

The second output acts as a signal/control output in order to dim the lighting device. With this option, system energy consumption can be optimized during cloudy/rainy/winter seasons.

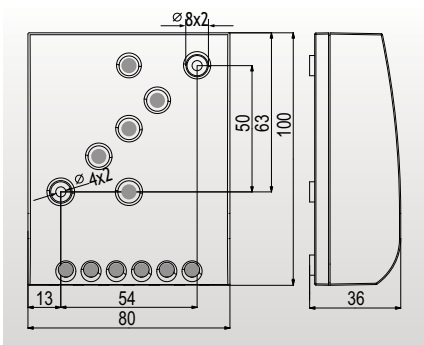

CML Solar Charge Controller

Phocos CML Series is One of the World's Best-Selling Small Solar Charge Controllers. Over 250,000 CML Controllers are Currently in Use in Numerous Projects Around the World.

- High-Efficiency Charging Process**
 Temperature compensation, three stage PWM series charging method. Sealed or vented batteries may be used.
- Improved System Indicators**
 Five LEDs indicate the PV, battery, load status and malfunctions. Acoustic signal alerts user to potential system malfunctioning.
- Complete Electronic Protection**
 Fully protected against reverse polarity, short circuit, overcurrent, overvoltage and reverse current flow at any of the controller terminals.

Technical Data	CML05/08/10/15/20
Nominal Voltage	12/24 V, automatic detection
Max. Solar Panel Current	5 A/8 A/10 A/15 A/20 A
Max. Load Current	5 A/8 A/10 A/15 A/20 A
Overcharge Protection	Constant voltage PWM series regulation: boost charge, float charge, optional equalization charge.
Overdischarge Protection	11.4-11.9/22.8-23.8 V controlled by state of charge(SOC)
Selectable LVD Modes	11.0/22.0 V controlled by fixed battery voltage
Ambient Temperature Range	-40 °C to +50 °C
Max. Wire Size	16 mm ² (AWG#6)
Self Consumption	4 mA
Weight	133-160 g

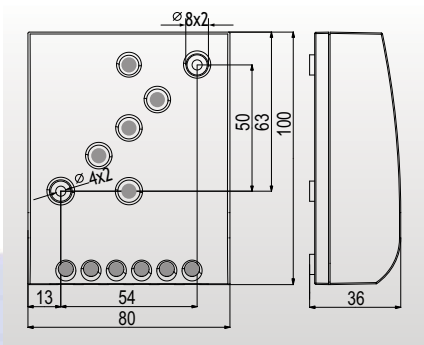
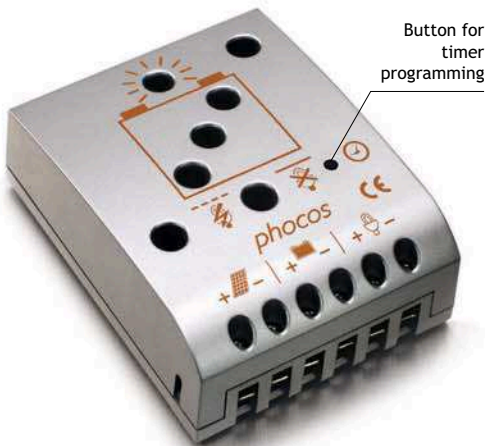

CMLNL Solar Charge Controller

Phocos CMLNL Controller is a Solar Lighting Controller for Street Lighting, Parking Lots and Bus-Shelters.

- Proven Reliability**
 CMLNL has the same electronic circuit and mechanical design as the famous CML controller.
- Greater Adaptability**
 Day/night threshold (light on/off point) can be detected automatically and adjusted according to prevailing on-site conditions and solar module array type.
- Fully Integrated Programmable Timer**
 Adjustable for shorter periods of up to 12 hours, or from dusk to dawn for all-night applications.

Technical Data	CML05/08/10/15/20NL
Nominal Voltage	12/24 V, automatic detection
Max. Solar Panel Current	5 A/8 A/10 A/15 A/20 A
Max. Load Current	5 A/8 A/10 A/15 A/20 A
Overcharge Protection	Constant voltage PWM series regulation: boost charge, float charge, optional equalization charge.
Overdischarge Protection	11.4-11.9/22.8-23.8 V controlled by state of charge(SOC)
Selectable LVD Modes	11.0/22.0 V controlled by fixed battery voltage
Ambient Temperature Range	-40 °C to +50 °C
Max. Wire Size	16 mm ² (AWG#6)
Self Consumption	4 mA
Weight	135-162 g
Button Function	*Long push to program all nightlight function settings *Short push in the day to verify the correct installation of the system

CM Solar Charge Controller



The CM Charge Controller is Designed Specifically for Use in Small Solar Systems Where the Load Disconnect Feature is not Required. The CM is Ideally Suited for Applications on Yachts and in Caravans.

- **Highly Efficient Battery Charging Capabilities**

PWM series regulation with integrated temperature compensation.

- **Extremely Reliable**

Solid state circuit, electronic fuse , PCB conformal coating for protection against harsh environment.

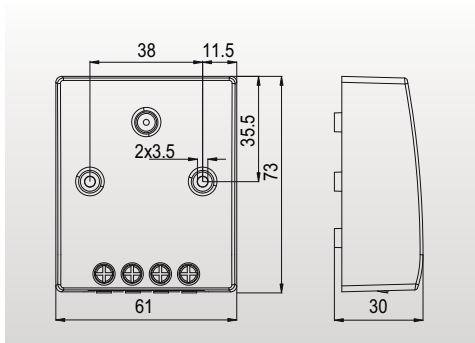

Technical Data	CM04	CM10
Nominal Voltage	12 V	12 V
Max. Solar Panel Current	4 A	10 A
Ambient Temperature Range	-40 °C to +50 °C	-40 °C to +50 °C
Max. Wire Size	16 mm ² (AWG#6)	16 mm ² (AWG#6)
Self Consumption	<4 mA	<4 mA
Weight	68 g	68 g

CA Solar Charge Controller



Phocos CA Controller is a Perfect Solution for Cost-Sensitive PV Systems (Particularly Those Used for Rural Electrification and Leisure Applications)

- **Advanced Electronic Design**

Temperature compensated two-stage PWM-series charging method. PCB conformal coating for humidity protection.

- **Complete Electronic Protection**

Anti-melting fuse. Fully protected against reverse polarity, short circuit, overcurrent, overload and reverse current.

- **Easy to Connect**

Large and rugged terminal block with anti-corrosive screws. Compact casing similar to that of the popular CML series.

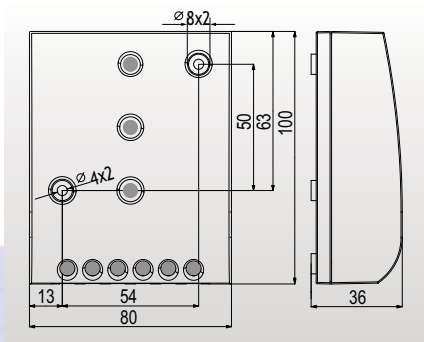

Technical Data	CA06	CA08	CA10	CA14
Nominal Voltage	12 V	12 V	12 V	12 V
Max. Solar Panel Current	5 A	8 A	10 A	14 A
Max. Load Current	6 A	8 A	10 A	14 A
Overcharge Protection	Constant voltage PWM series regulation: boost charge, float charge			
Overdischarge Protection	Controlled by fixed battery voltage (11.5V)			
Ambient Temperature Range	-40 °C to +50 °C			
Max. Wire Size	16 mm ² (AWG#6)			
Self Consumption	4 mA			
Weight	145-148 g			

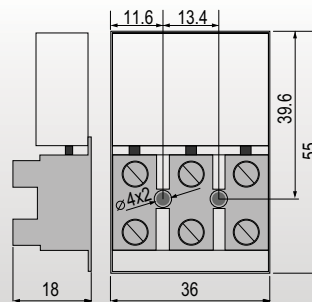

PR Solar Charge Controller

Phocos PR Series of Charge Controllers is a Two-Stage Charge Controller Designed to Charge Lead Acid Batteries. Fully Sealed within a Robust Casing, the PR is Able to Withstand Continued Exposure to Sea Air.

- **Ideal for Marine Application**

Totally sealed construction for outdoor use, brass screws and epoxy resins potted circuit.

- **Heat Resistant Design**

Able to withstand temperatures of up to 70 °C .

Technical Data	PR1210	PR1210L	PR2410	PR2410L
Nominal Voltage	12 V	12 V	24 V	24 V
Max. Solar Panel Current	10 A	10 A	10 A	10 A
Battery Type	Vented	Sealed	Vented	Sealed
Ambient Temperature Range	-20 °C to +70 °C			
Max. Wire Size	14.5 mm ²			
Self Consumption	4 mA			
Weight	50 g			

* The PR has no load connection and blocking diode.

DIN Rail Mounting

A DIN Rail Mounting Plate (CX-DR2) is Available as an Accessory. This Allows the Controller to be Mounted on a Standard 35mm DIN Rail. Screws are Supplied with the Mounting Plate.

- **CX, CXN Installation**

Length(min): 12 mm
DiameterØ: 2.9 mm

- **Screw Head**

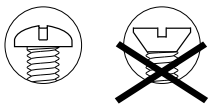

Do not use countersunk head screws.

- **CML, CMLNL, CA, BCM, DCL, DCS Installation**

Length(min): 16 mm
DiameterØ: 2.9 mm



IP Protection

Higher IP protection can be achieved by using different IP cases.



PL Solar Charge Controller

Phocos PL Series Charge Controller Gives You the Freedom to Operate Your Solar Electric System the Way You Want to.

- **Informative**

Display shows battery voltage, charge current, ampere hours in and out of battery, load being drawn from the battery and charge cycle status.

- **Intelligent**

PL stores data for the last 30 days.

- **Well Connected**

With the optional PLI interface and PLCOM software, the user can access the controller from a computer. Data can be read or settings adjusted remotely.

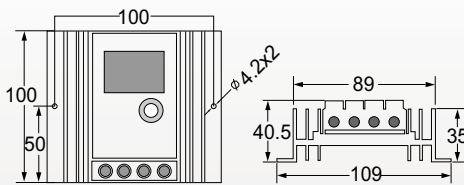

PL20

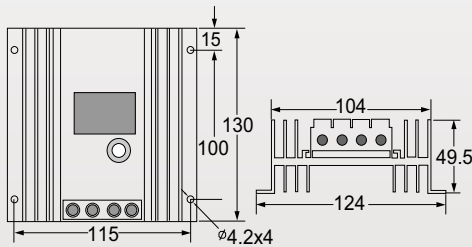

PL40

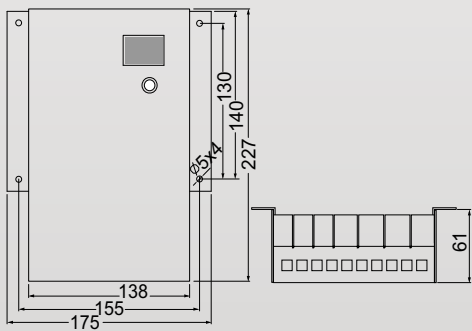

PL60

Technical Data	PL20	PL40	PL60
Nominal Voltage	12, 24, 32, 36, 48 V		
Max. Solar Panel Current	20 A	40 A	60 A
Max. Load Current	20 A	7 A	30 A
Regulation Set Points	4 pre-set programs or user adjust		
Weight	320 g	515 g	1100 g
Ambient Temperature Range	-20 °C to +55 °C		
Max. Wire Size	30 mm ²		

Accessories

PLA: Multi-PL Control Unit

The PLA allows up to three PL series charge controllers to work together. The PLA provides a common communication interface, four alarms or control channel outputs, and control over a separate load control unit called an LS1(50 A).

The PLA makes the retrieval of system performance data easier by providing a PC compatible method of collecting all relevant information on the system.

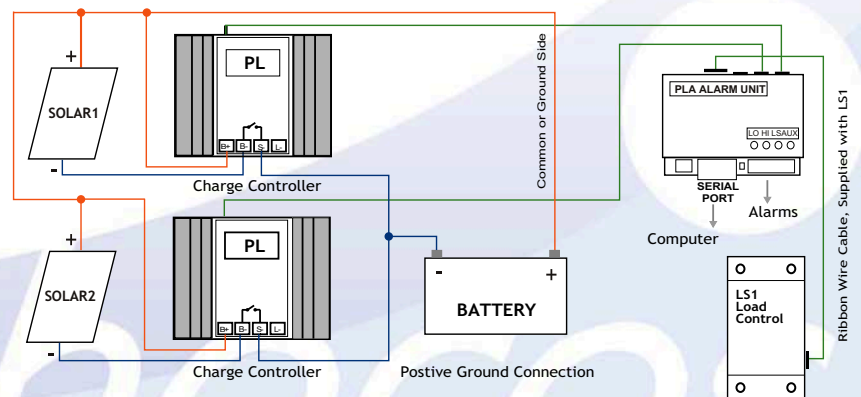

PLS Shunt Adaptor

The PLS shunt adaptor is designed for use with PL series solar charge controllers. It allows the controller to measure charge or load currents which do not go through the controller. This allows inverter or generator currents to be included in the controller's display. The PLS shunt adaptor measures the voltage across a current shunt and converts that measurement into digital form. This data is then sent to the PL controller. Two shunts can be used.

PL Solar Charge Controller

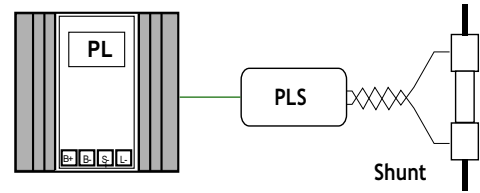

PLI Computer Interface: RS232 Interface for PL series controllers

The PLI is a device which allows the PL series solar controllers to communicate with a computer. It converts the signals from the PL into a form which a computer can recognize. It also converts signals from the computer to suit the PL controller.

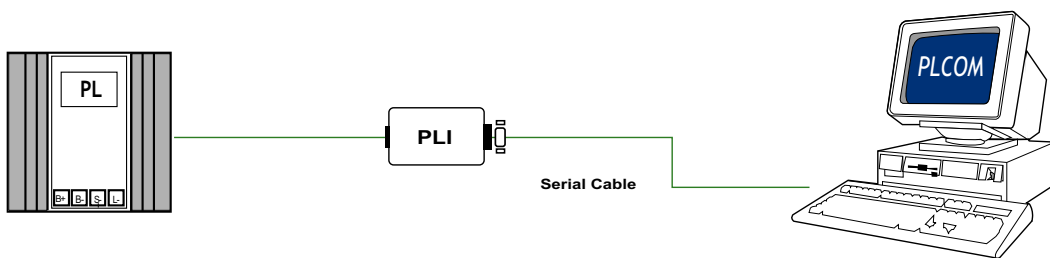

PLCOM Software

PLCOM is a Windows-based program which enables communication with the PL controller and helps in system performance analysis.

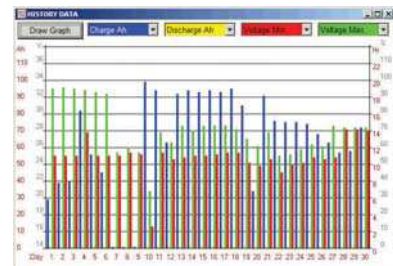

Hybrid Power System

Although the PL is primarily a device to control the charging of batteries from the solar panel, it can also be used with other energy sources such as wind, microhydro and fuel driven generators.

The PL supports series and shunt control. Shunt control is appropriate for wind generators or microhydro system which requires a constant dump load. In a hybrid system, the solar component can be controlled by the SOL-input and the other energy sources by the shunt control which is done through the LOAD or "G" terminals.

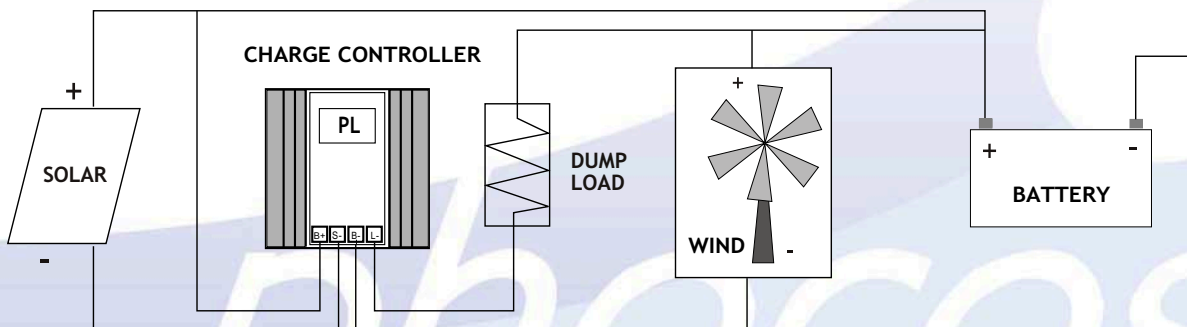

DINGO Solar Charge Controller

The Dingo 20/20 inherits many of the best feature of the PL series of controllers.

- Reliable, easy to understand, one button interface and proven, easy to learn menu structure.
- Symmetrical charge and load currents, both 20A.
- Industry standard four stage charging regime.
- 12,24,32,36 and 48V selectable. Only one controller to stock.
- Unbeatable high temperature performance. Full charge and full load current, without interruption to operation, in a 50 °C ambient. All day, every day.
- Fast, reliable, affordable, Phocos Service, long after the long warranty has expired.

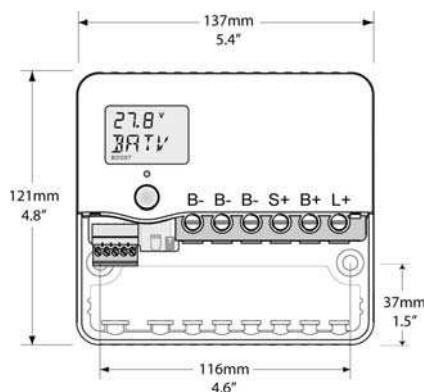

Technical Data	Dingo20/20
Nominal Voltage	12, 24, 32, 36, 48 V
Max. Solar Panel Current	20 A
Max. Load Current	20 A
Regulation Set Points	4 pre-set programs or user adjust
Weight	405 g
Ambient Temperature Range	-20 °C to +55 °C
Max. Wire Size	16 mm ² (6 AWG)
Self consumption	9 mA @ 12 V, max 26 mA @ 60 V

The Negative Ground makes it much easier to use in vehicles and easier to understand for people used to working with vehicle systems. A rugged new bus uses the MODBUS protocol (industrial automation standard proven in noisy environments). It is compatible with Modular System Components. This gives unprecedented flexibility in system design.

More Data Storage. 512 days worth of data can be stored. That's 16 Months worth of Charge and Load Ah,

Battery voltage range, and daily State of Charge. Data for 99 days is accessible via the display so if you don't have a computer, you're not locked out.

LED backlighting makes the display readable in any light conditions.

Hidden Wiring. All the wires are covered. Wiring to the unit can be kept out of sight inside the wall obehind the mounting panel. This makes for a clean installation.

Generator Terminals. Voltage free contacts, as required by many generator start systems, are now included in the basic controller.

Material:

Case: Polycarbonate
Heatsink: Anodised Aluminium

Weight (in box): 455g (11b)

Dimensions:

Width 137mm (5.4")
Height 121mm (4.8")
Depth 45mm (1.8")
Mounting hole spacing 116mm (4.6")
Mounting hole size 5mm (3/16")

CMM Remote Display

Phocos CMM Remote Display is Designed to Measure and Display Current Values of the PV System.

- For Phocos CA, CML and CMLNL
- Multifunctional LCD Display
Measure and display panel current, load current and battery voltage by three digit LCD display
- Easy to Select
Three-position switch to select which value to be displayed
- Prepared for DIN Rail and Wall mounting

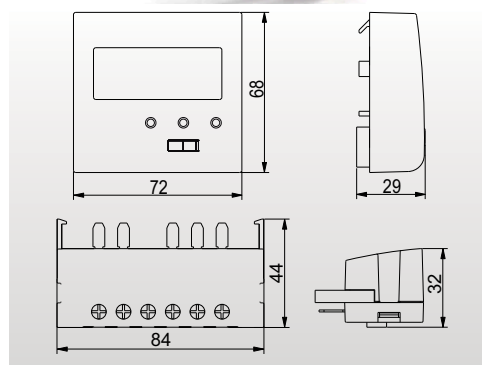

Technical Data	CMM
Voltage Range	Display voltage range of Phocos controller
Current Range	Display current range of Phocos controller
Operating Temperature Range	-25 to +50 °C
Length of Connecting Wire	2 m
Weight	194 g (with connecting wire)

CXM Remote Display

Phocos CXM Can be Used in Combination with Phocos CXN Series Charge Controllers to Display Current Values and Historical Data.

- For Phocos CXN
- Multifunctional LCD Display
Display PV/load current, battery voltage, SOC% and daily PV/load Ah. Seven days of datalogger values are also accessible.
- Easy to Select
Two push buttons to cycle through displayed data.
- Prepared for DIN Rail and Wall Mounting

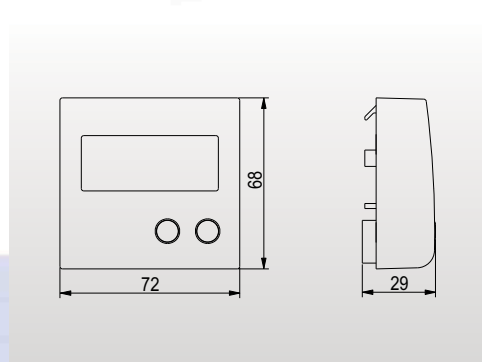

Technical Data	CXM
Voltage Range	Display voltage range of your CXN
Current Range	Display current range of your CXN
Operating Temperature Range	-25 to +50 °C
Length of Connecting Wire	2 m
Weight	94 g (with connecting wire)

BCM DC Battery Charger

Phocos BCM is an Innovative Charger for AA-Size Rechargeable NiMH and NiCd Batteries.

- **Accurate Battery Charging:**

Special voltage and current limitation features ensure a smooth charging process for AA-size rechargeable batteries.

- **Excess Energy Management**

The BCM enables the efficient use of excess energy in the PV system.

* The 4 AA-size rechargeable batteries in the picture are not included.

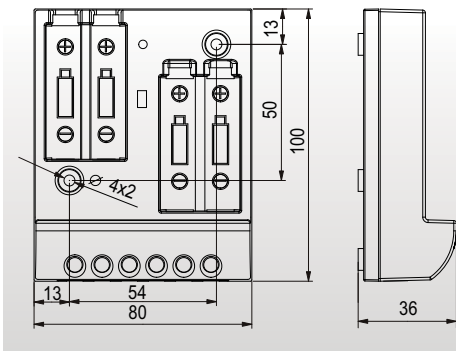

Technical Data	BCM
Input Voltage Range	10.5-15 V
Norminal Output Voltage	4 x 1.5 V
Max. Charging Current	< 60 mA
Battery Capacity	500 mAh-2500 mAh
Ambient Temperature Range	-40 °C to +50 °C
Max. Wire Size	16 mm ² (AWG#6)
Weight	140 g



DCS DC Voltage Converter

Phocos DCS Adjusts the Voltage to Below 12 V for Certain DC Appliances Such as Radios, Cassette Players, etc.





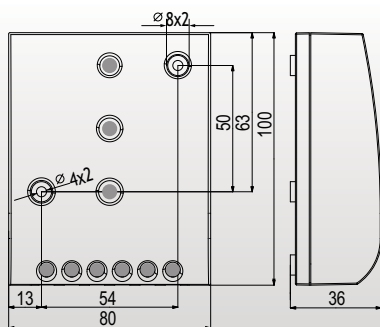

DCL DC Voltage Converter

- **Excess Energy Management**

Beside all functions of DCS, the DCL is designed to charge the second battery in your solar system using the excess energy from the solar module.



Technical Data	DCS and DCL
Nominal Voltage	12 V
Output Voltage @ Output Current	1.5V@250 mA / 3V@300 mA / 4.5V@400 mA / 6V@450 mA / 9V @ 650 mA / 12V @ 1000 mA / 13.6V @ 2000 mA
Additional DCL Data	Second battery float voltage: 13.4 V Max. charge current: 2 A @ 13.4 V
Ambient Temperature Range	-40 °C to +50 °C
Weight	142 g / 152 g

Feature		Model							
Main Feature	System Voltage	12 V	12 V	12 V	12/24 V	12/24 V	12/24 V	12/24 V	12/24/32/36 48 V
	Rated Solar Current	4, 10 A	5, 8, 10, 14 A	5, 8, 10, 15, 20 A	10, 20, 40 A	5, 10, 20 A	5, 10, 20 A	5, 10, 20 A	20, 40, 60 A
	Rated Load Current	None	6, 8, 10, 14 A	5, 8, 10, 15, 20 A	10, 20, 40 A	5, 10, 20 A	5, 10, 20 A	5, 10, 20 A	20, 7, 30 A
Overcharge Protection	Charging Regulation	Shunt	Series	Series	Series	Series	Series	Series	Series or Series & Shunt
	PWM Battery Charging	✓	✓	✓	✓	✓	✓	✓	PWM or "On-Off"
	Temperature Compensation	✓	✓	✓	✓	✓	✓	✓	Pre-set or user adjust
	Equalization Charging	—	—	✓	✓	✓	✓	✓	Pre-set or user adjust
	Boost Charging	✓	✓	✓	✓	✓	✓	✓	Pre-set or user adjust
Over Discharge Protection	Vented or Sealed Battery	✓	✓	By Jumper	By Menu	Infrared remote control	Infrared remote control	Pre-set or user adjust	Pre-set or user adjust
	Control Mode	—	Voltage	Voltage or SOC	Voltage or SOC	Voltage or SOC	Voltage or SOC	Voltage, pre-set or user adjust	—
Communication Capability	Battery Sulfation Protection (Adaptive Low Voltage Disconnect)	—	—	—	✓	—	✓	✓	—
	Display (Battery and Load Status)	1LED	3LEDs	5LEDs	Graphic LCD	LED	Graphic LCD	LED	Digital LCD
	Acoustic Warning	—	—	✓	✓	—	✓	—	—
	Manual Load Disconnect	—	—	—	✓	—	✓	—	—
	Data Logging with Optional Computer Interface	—	—	—	USB	—	—	—	RS232C
Safety Protection	Reverse Polarity Protection	✓ (No load)	✓	✓	✓	✓	✓	✓	✓
	Short Circuit Protection	Electronic fuse	Electronic fuse	Electronic fuse	Electronic fuse	Electronic fuse	Electronic fuse	Electronic fuse	Electronic fuse
	Over Temperature Protection	—	—	—	✓	—	✓	✓	✓
	Over Voltage Protection	✓ (No load)	✓	✓	✓	✓	✓	✓	✓
	Overcurrent Protection	—	Load only	Load only	PV and load	Load only	Load only	Load only	PV and load
	Reverse Current Protection	✓	✓	✓	✓	✓	✓	✓	✓
	Night Light Function	—	—	—	✓	—	✓	✓	✓
Other Features	External Temperature Sensor	—	—	—	✓	—	✓	✓	✓
	PCB Conformal Coating	✓	✓	✓	✓	✓	✓	✓	✓
	Ambient Temperature Range	-40 to 50 °C	-40 to 50 °C	-40 to 50 °C	-25 to 50 °C	-40 to 60 °C	-40 to 60 °C	-40 to 60 °C	-20 to 55 °C
	Max. Wire Size	16 mm ²	16 mm ²	16 mm ²	16 mm ²	2.5 mm ²	2.5 mm ²	2.5 mm ²	PL:30 mm ² ; Dingo:16mm ²
	IP Protection	IP22	IP22	IP22	IP22	IP68	IP68	IP68	IP22
Grounding	Positive	Positive	Positive	CX:Positive;CXN:Negative	Positive	Positive	Positive	PL:Positive; Dingo:Negative	
Certificate	CE	CE, World Bank	CE, World Bank	CE	CE	CE	CE	CE	



CFL Compact Fluorescent Lamp

Wherever low cost, high quality, high lumen efficiency are critical factors for low-voltage lighting, you will find the Phocos CFL lamp. The sophisticated ballast electronics provide world-class features and reliability and are installed in numerous projects worldwide.

- **Two Different Light Colors Available (2700 K, 6400 K)**
- **Quality Pays Off**
High lifespan and high lumens efficiency provides the lowest overall system cost.
- **Extended Lifespan**
Preheating feature drastically extends lifespan allowing more than 50,000 switching cycles (equivalent to 10,000 operation hours).
- **Over-temperature Protection**
This safety feature protects lamp from damage in high-ambient temperature conditions.
- **Detachable Tube Versions Available**
Reusable ballasts for detachable tube CFLs are guaranteed to last 30,000 hours. Inexpensive, replaceable tubes make lamp replacement simple and cost-effective. Ballast carries a standard 5-Year Factory Warranty.
- **Wide Operation Voltage Range**
A wide operation voltage range ensures safe start-up even when battery voltage is slightly lower or higher than typical conditions.

Technical Data	CL1203 W/C	CL1205 W/C	CL1207 W/C	CL1209 W/C	CL1211 W/C	CL1215 W/C	CL1230 W/C	CL2407 W/C	CL2415 W/C
Voltage Range	11-15 V	11-15 V	11-15 V	11-15 V	11-15 V	11-15 V	11-15 V	20-30 V	20-30 V
Nominal Power	3 W	5 W	7 W	9 W	11 W	15 W	30 W	7 W	15 W
Average Light Intensity	100 lm(W) 100 lm(C)	250 lm(W) 250 lm(C)	350 lm(W) 350 lm(C)	520 lm(W) 520 lm(C)	670 lm(W) 630 lm(C)	950 lm(W) 925 lm(C)	1500 lm(W) 1500 lm(C)	350 lm(W) 350 lm(C)	900 lm(W) 900 lm(C)
Ambient Temperature Range	-10 ~ +50 °C	-10 ~ +50 °C	-10 ~ +50 °C	-10 ~ +50 °C	-10 ~ +40 °C	-10 ~ +40 °C	-10 ~ +35 °C	-10 ~ +50 °C	-10 ~ +40 °C
Equivalent Brightness (Incandescent Lamp)	15W	25W	40W	50W	65W	100W	150W	40W	100W

Available as Detachable Tube

Technical Data	CL1205W/C D	CL1207W/C D	CL1211W/C D	CL1215W/C D
Voltage Range	11-15V	11-15V	11-15V	11-15V
Nominal Power	5W	7W	11W	15W
Average Light Intensity	240lm(W) 240lm(C)	360lm(W) 350lm(C)	650lm(W) 620lm(C)	900lm(W) 900lm(C)
Ambient Temperature Range	-10 ~ +50 °C	-10 ~ +50 °C	-10 ~ +40 °C	-10 ~ +40 °C
Equivalent Brightness (Incandescent lamp)	65W	40W	65W	100W

* E27 / Edison is available.

* Light temperature: warm color(W) / cool color(C).

CF Lamp With Housing



Proven Phocos CFL ballast technology combined with rugged housing and detachable tube is the all in one solution for any DC-Lighting application. With more than 50.000 switching cycles this lamp has a life span of at least 10,000 hours.

- Two Different Light Colors Available (2700 K, 6400 K)
- Quality Pays Off
- Plastic housing protects fragile CFL tube from breakage and insect inhabitation.
- Clear plastic cover ensures full brightness.
- Switch, cables and mounting screws included.
- Detachable tube increases cost-effectiveness.

Technical Data	CF1209W/C	CF1211W/C
Voltage Range	11-15 V	11-14.5 V
Nominal Power	9 W@12.5 V	11 W@12.5 V 900 mA
Light Intensity	Up to 450 lm(W) Up to 450 lm(C)	Up to 550 lm(W) Up to 550 lm(C)
Ambient Temperature Range	-10 ~ +50 °C	-10 ~ +50 °C
Equivalent Brightness (Incandescent lamp)		

LED

With an infinite number of switching cycles and low power consumption, Phocos' new LED technology allows you to minimize overall system costs.



- Extremely low power consumption
- Over 80% of luminosity retained after 7000 hours
- Withstands shock and vibration
- Perfect for systems with small load requirements

lm/W Luminous Efficiency Comparison

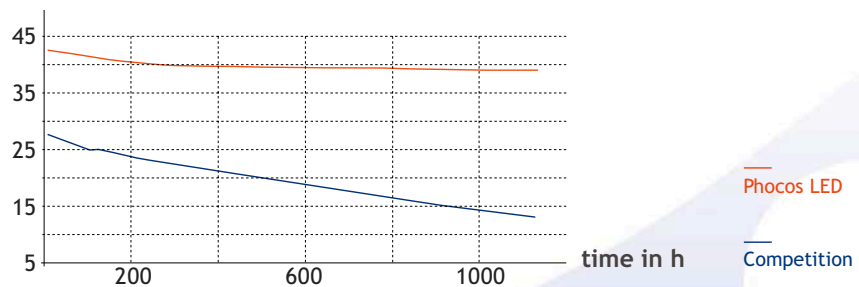

Technical Data	SL1210WF22	SL1210CF40
Voltage Range	11-15 V	11-15 V
Nominal Power	1.0 W	1.0 W
Light Intensity	22 lm	40 lm
Radiation Angles	60 °	40 °
Color	Warm	White
Equivalent Brightness (Candle)		

090804
Subject to change without notice

* E27 / Edison is available.

* Light temperature: warm color(W) / cool color(C).

TFT-LCD TV/Monitor



Phocos TV is a TFT-LCD color TV receiver/monitor with very low power consumption, and can be used directly in the 12 V solar system.

- **Very low power consumption**

Operation Power consumption: 5 W . Standby Power consumption: 1 W

- **Auto Search**

Compatible Signals: CATV, VHF-L, VHF-H, UHF. The receivable channels of TV are: VHF-L (48.25 MHz to 147.25 MHz); VHF-H(154.25 MHz to 423.25 MHz); UHF(431.25 MHz to 863.25 MHz).

- **Multi-language Menu**

German, English, Spanish, French, Portuguese, Chinese.

- **Wide Operating Voltage Range, 11 - 15 V**

Technical Data	TV07	TV15
Screen Size	7 In	15 In
Nominal Input Voltage	12 V	12 V
Display Model	16:9/4:3	16:9/4:3
Resolution	480 x RGB x 234	1024 x RGB x 768
Brightness	300 cd/m ²	250 cd/m ²
Contrast Rate	300:1	500:1
Operation Temperature range	0 to +40 °C	-10 to +50 °C
Dimensions	205x147x40 mm	280x355x50mm
Weight	0.5 Kg	2.2 Kg

DC Refrigerator/Freezer



Phocos' high efficiency refrigerators and freezers have exceptionally low energy consumption requiring smaller, less expensive power systems and low operating expense.

- **Environmentally friendly CFC-free refrigerant (R-134a)**

- **Energy Efficient Refrigeration**

Have exceptionally low energy consumption requiring smaller, less expensive power systems and low operating expense.

Technical Data	FR165R/F	FR225R/F	FR50R
Input Voltage	12/24V DC	12/24V DC	12/24V DC
Energy Required at 21 °C Refrigerator/Freezer	96/300Wh/day	120/480Wh/day	50/150Wh/day
Energy Required at 32 °C Refrigerator/Freezer	168/444Wh/day	204/540Wh/day	85/250Wh/day
Capacity	165 L	225 L	50 L
Ambient Temp. Range	-10 to +43 °C	-10 to +43 °C	-10 to +43 °C
Dimensions	98x76x98 cm	124x76x98 cm	83x71x63 cm
Weight	51 Kg	59 Kg	34 Kg



RoHS | CE

ISO9001:2000

phocos